

INSTALLATION AND WARRANTY INSTRUCTIONS

IT IS THE RESPONSIBILITY OF THE INSTALLER TO INFORM THE END USER OF THE INSTALLATION, MAINTENANCE & REPAIR REQUIREMENTS FOR THIS WATER HEATER IN ACCORDANCE WITH SANS 10254 AND THE MANUFACTURERS REQUIREMENTS.

INSTALLATION INSTRUCTIONS - PLUMBING TO BE INSTALLED BY A QUALIFIED PLUMBER AND TO COMPLY WITH SANS 10254 & 10252-1

INSTALLER TO ISSUE A PLUMBING CERTIFICATE OF COMPLIANCE

This water heater must be fitted with the supplied TP VALVE before installation. Always fit this water heater with a PRESSURE CONTROL VALVE and EXPANSION CONTROL VALVE (which may be combined in one unit) not exceeding the kPa rating of the water heater as stated on the serial label. TP VALVE and EXPANSION VALVE overflow pipes must be led separately to the outside of the building in a continuous downward direction and in a frost free ambient with the outlets being left open to the atmosphere, and in case of the TP VALVE must be copper. The EXPANSION VALVE is designed to drip under normal operating conditions and must never be plugged.

1. Flush the cold water supply line prior to connecting the water heater.
2. Ensure the orientation of the drain cock is as indicated, to avoid the pipes obstructing the flange area.
3. Check that the control valve is free from dirt and should be of correct pressure rating.
4. Ensure all piping and water heater brackets are securely fixed.
5. After completing the installation, fill the water heater and open one or more hot water taps to dispel the air from the system.
6. Close all hot taps to bring water heater under pressure and check all plumbing connections for leaks.
7. Installation diagrams must be complied with in all respects.
8. The installation of a drip tray is required where water leaking from the water heater or connections could cause consequential damage.

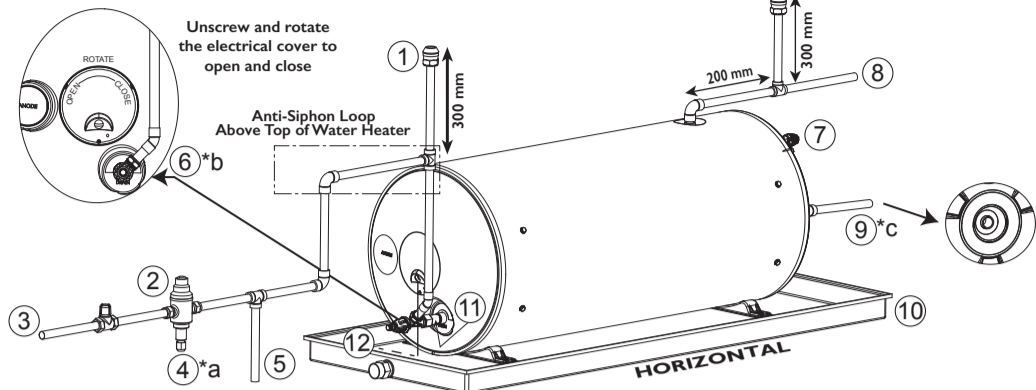

ALL PIPE WORK AND COMPONENTS CONNECTED TO THE INLET, OUTLET AND T&P VALVE INCLUDING T&P VALVE AND DRAIN COCK SHOULD BE THERMALLY INSULATED FOR 2 METERS. THE THERMAL INSULATION SHALL COMPLY WITH THE REQUIREMENTS OF SANS 10252-1, SANS 10254, SANS 10400-XA AND SANS 204

INSTALLATION INSTRUCTIONS - ELECTRICAL ELECTRICAL WORK TO BE CARRIED OUT BY A QUALIFIED ELECTRICIAN AND TO COMPLY WITH SANS 10142-1

WARNING: THIS APPLIANCE MUST BE EARTHED & BONDED

1. Heat resisting round 2.5mm² (minimum) 3 core stranded cable should be used to connect the electrical supply.
2. A double pole isolator switch to be installed within 1m of the water heater - correctly rated for the element size.
3. Circuit breaker on distribution board to be correctly rated for the element size.
4. Turn off the circuit breaker on the distribution board as well as the isolator at the water heater.
5. Remove the electrical access panel by removing the screw and rotate anti-clockwise.
6. Cut away tips of old electrical wire, stripping away the insulation.
7. Connect and tightly secure electrical connection to the thermostat / terminal block. Ensuring thermostat is tightly inserted into the element.
8. Replace electrical access panel by aligning the hooks in the slot and rotate clockwise and then fix with screw.
9. Ensure the water heater is full of water before switching on electricity, even for testing purposes.
10. Heating element will burn out if turned on without water.

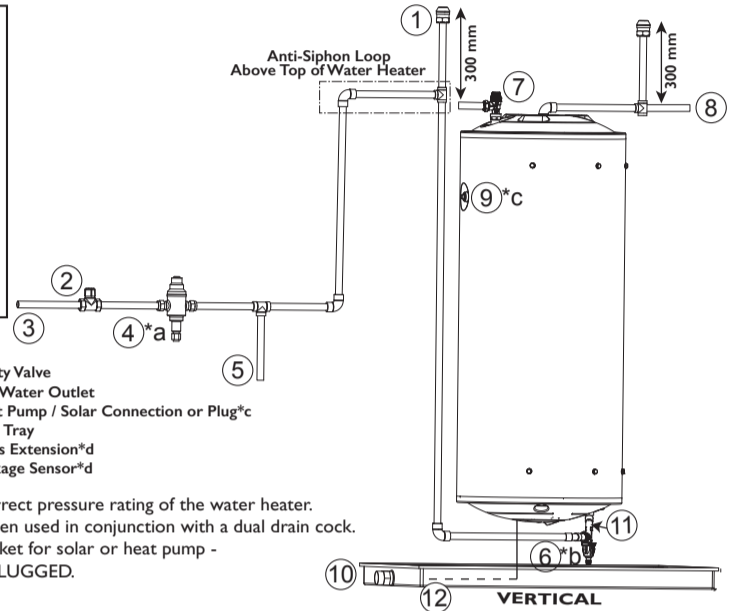
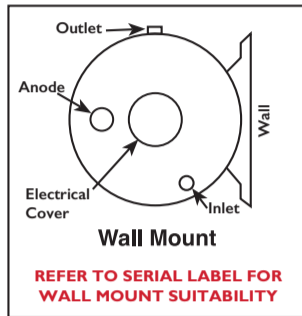

- 1) Vacuum Breaker
- 2) Stopcock
- 3) Mains Pressure
- 4) Pressure Control Valve^a
- 5) Balanced Cold Water
- 6) Drain Cock^b
- 7) Safety Valve
- 8) Hot Water Outlet
- 9) Heat Pump / Solar Connection or Plug^c
- 10) Drip Tray
- 11) Brass Extension^d
- 12) Leakage Sensor^d

^a Refer to the serial label for the correct pressure rating of the water heater.

^b Solar or heat pump compatible when used in conjunction with a dual drain cock.

^c When not using the additional socket for solar or heat pump - ENSURE THAT THE SOCKET IS PLUGGED.

^d Supplied on certain models only.

The following minimum installation clearance must be considered on the electrical / flange side of the water heater in the event of removing element, thermostat or anodes and 500mm on the opposite side in case for T&P valve.

50L - 500mm	100L - 700mm	150L - 950mm	200L - 1100mm	250L - 1300mm
-------------	--------------	--------------	---------------	---------------

INSTALLATION INSTRUCTIONS - MOUNTING

Floor Mounting

Water heater can be installed on floor or on the ceiling horizontally. Floor stand is available with Ariston which can be used to install the product vertically on the floor. Please make sure to fix the bracket to the wall while using the floor stand.

Wall Mounting - Horizontal

Maximum wall mount capacity is 200L. The strength and the stability of the wall should be verified by a certified construction person. When wall mounting a 200L, Ariston recommends additional support.

1. Remove bracket from floor mounting position and fix it on the side of the casement.
2. Bolt unit to the wall using suitable rated fixation bolts.

Wall Mounting - Vertical

Maximum wall mount capacity is 150L. The strength and the stability of the wall should be verified by a certified construction person.

1. Bracket remain in the same floor mounting position.
2. Bolt unit to the wall using suitable rated fixation bolts.

200L UNIT MUST NOT BE WALL MOUNTED VERTICALLY
250L UNIT MUST NOT BE WALL MOUNTED HORIZONTALLY OR VERTICALLY
ELECTRONIC PRODUCTS MUST NOT BE INSTALLED OUTDOOR

MAINTENANCE INSTRUCTIONS

SWITCH OFF ELECTRICAL SUPPLY BEFORE ATTEMPTING ANY MAINTENANCE OR REPAIRS ON THE WATER HEATER

REPLACEMENT OF THERMOSTAT

1. Disconnect wiring, remove thermostat by pulling it out of its pocket.
2. Fit new thermostat, ensuring the stem of the thermostat is not bent or damaged in any way. On electronic models, ensure that the metallic thermostat bulb is inserted before the wired probe.
3. Reconnect wiring to thermostat ensuring connections are clean, tight and secure.
4. Set thermostat to 60°C or as required by user.

REPLACEMENT OF ELEMENT

1. Switch off the inlet water supply.
2. Drain the water by opening the valve on the drain cock.
3. Remove thermostat as above and remove flange lid from cylinder.
4. Remove old element and gasket from flange lid.
5. Fit new element and gasket to flange lid.
6. Refit flange lid, and replace thermostat as above.

REPLACEMENT OF ANODE

1. Switch off cold water supply and drain water heater.
2. Remove anode cover and unscrew anode from cylinder.
3. Fit new anode and replace anode cover.

THE ANODE IS A MAINTAINABLE COMPONENT

ANODE INFORMATION

1. The anode installed in a vitreous enamel lined steel water heater will slowly dissipate whilst protecting the cylinder.
2. The life of the cylinder may be extended by replacing the anode.
3. Fitment of an Aluminium anode is recommended for harsh water condition including borehole or well water.
4. Inspect the anode yearly, and if required, replace the anode.
5. Replacement of the anode must be carried out at minimum 2 year intervals, to ensure protection of the steel cylinder.
6. The life expectancy of the anode would be dependent on the water quality in the area, which the water authority can advise on.
7. A guideline below (as reference only):

TOTAL DISSOLVED SOLIDS PPM	RECOMMENDED REPLACEMENT
0 - 400	3 Years
400 - 600	2 Years
Over 600	1 Year

Fitment of an aluminium anode is recommended for harsh water conditions.

8. When water is supplied from a borehole or well, anodes should be replaced at least once a year.

WARRANTY ^{T & C Apply}

This water heater is warranted against faulty materials and/or workmanship not withstanding anything to the contrary contained herein. The company will repair or at its own discretion, replace a defective unit or parts inclusive of labour costs during the warranty period. The repaired or replaced part, or water heater, warranty will still be calculated from original date of manufacture, not from the repaired or replacement date.

The period of warranty is calculated from the date of manufacturing as indicated on the serial plate. This is the only warranty given and it expressly excludes all other warranties, expressed or implied by law. The warranty expressly covers the water heater only and does NOT cover any other part or parts of the installation which may, because of the failure or defect of the water heater become damaged in any way whatsoever and under no circumstances shall the manufacturer be liable for any direct, indirect or consequential loss suffered by the consumer and/or third party.

The warranty is subjected to the following:

- (a) The water heater is installed in accordance with the manufacturers installation requirements and with SANS 10142-1: (Electrical) and SANS 10254 & 10252-1 (Plumbing) and in accordance with any other applicable national and local regulations.
- (b) The water heater is maintained and serviced yearly.
- (c) The anode is inspected yearly and replace as required, if not the anode should be replaced every second year.
- (d) The serial plate is not damaged or tampered with in any way.
- (e) The water heater is subjected to normal use with municipal water supply and proper installation by qualified personnel.
- (f) This warranty excludes:
 - any failure due to damage, accidental or otherwise, to the water heater or any other component, including: failure due to misuse, neglect or poor maintenance; incorrect installation; normal wear and tear; corrosion, rusting or stains.
 - the failure of the water heater or component directly or indirectly as a result of excessive water supply pressure, corrosive or harsh water conditions or corrosive atmosphere.
 - the water heater replacement is requested for reasons of noise, taste, odour, discoloration and / or rust.
- (g) Elements burnt out due to no water, or element and thermostat terminals that are burnt or melted are excluded from this warranty.
- (h) The above warranty is subject to only genuine replacement parts being used whilst the inner cylinder is still under warranty.
- (i) The above warranty shall however be completely invalidated if any repairs are effected by the customer or others on their behalf in an attempt, to remedy the alleged fault.
- (j) The water heater is not allowed to be relocated from its original installation location and under no circumstances must the unit be removed from the installation.
- (k) Sufficient access to the water heater for either repairs or replacement is the responsibility of the end user. The manufacturer will not make good or reassemble any ceilings or cupboards.
- (l) As per SANS 10254, no one-way valve or stop cock is allowed between the water heater and the expansion relief valve.



SCAN ME TO DOWNLOAD

WARRANTY PERIODS ^{T & C apply}

Cylinder	5* Years
Electrical Components	1 Year
Gaskets	1 Year
Drain Cock and T&P Valve	2 Years
Anode (consumable, service required)	None

*Subject to maintenance of anode as indicated in 'Anode information' section.

*Warranty only applicable in South Africa, Swaziland, Lesotho, Botswana & Namibia.

ARISTON

After-Sales Service: 010 745 9911 / service.za@aristonthermo.com